



GAI-TRONICS® CORPORATION
 A HUBBELL COMPANY

Model 293-001, 293AL-001, 297-001, 298-001, and 294AL-001 Emergency Phones

TABLE OF CONTENTS

Getting Started 1

Product Overview 1

Standard Operation..... 3

 Placing an Emergency Call..... 3

 Placing a Non-Emergency Call (Models 294AL-001 and 298-001 Only)..... 3

Americans with Disabilities Act (ADA) Functionality..... 4

Installation5

Safety Guidelines 5

General Installation Guidelines..... 5

 Tamper-Resistant Hardware 5

 Conduit Installation Details 6

Models 293-001, 293AL-001, and 294AL-001 7

Models 297-001 and 298-001 9

Setup 12

Hardware Configuration..... 12

Audio Level Adjustments 14

Programming 16

Remote Programming 16

Local Programming..... 17

Programming Sequences 19

 Dialing Options..... 19

 Password 21

 Silent Monitoring Feature..... 21

 Off-Hook Ringing..... 21

 Disconnect Options..... 22

 Americans with Disabilities Act (ADA) Programming..... 23

 Automatic Line Level Compensation for Optimum Audio Performance 23

Maintenance..... 25

Specifications 26

Confidentiality Notice..... 29

Model 293-001, 293AL-001, 297-001, 298-001, and 294AL-001 Emergency Phones

Getting Started

Product Overview

Thank-you for your purchase of a GAI-Tronics ADA-compliant emergency telephone. This manual applies to the following GAI-Tronics ADA-Compliant Emergency Telephones:

| Model | Description |
|------------------|---|
| 293-001 | Emergency Phone – This phone is housed in a safety yellow, glass-reinforced polyester enclosure that is designed to be surface-mounted and includes an emergency push button. |
| 293AL-001 | Emergency Phone – The vandal-resistant phone is housed in a cast aluminum enclosure painted safety yellow that is designed to be surface-mounted and includes an emergency push button. |
| 294AL-001 | Emergency Phone with Keypad – A cast aluminum enclosure painted safety yellow that is designed to be surface-mounted and includes a 12-button Braille keypad, an emergency push button and a call (off-hook) button. |
| 297-001 | Flush-panel Emergency Phone – This is a flush-mount phone with a heavy-gauge brushed stainless steel front panel, and includes an emergency push button. |
| 298-001 | Flush-panel Emergency Phone with Keypad – This flush-mount phone with a heavy-gauge brushed stainless steel front panel includes a 12-button Braille keypad, an emergency push button, and a call (off-hook) button. |

All of the emergency telephones listed above comply with the Americans with Disabilities Act (ADA). Each phone includes a Braille tag for vision-impaired individuals to identify the functions of the telephone and a visual indication for hearing-impaired individuals indicating that an emergency call has been answered.

The CALL RECEIVED WHEN LIT LED is the visual call-received indicator. When the security officer answers the telephone and acknowledges the call, the LED will light. The LED remains on until the call is disconnected.

The GAI-Tronics emergency phone product line provides the flexibility to address a diverse range of applications. A wide variety of functions can be achieved by altering the configuration data stored in the phone's non-volatile memory. These configuration options include:

- Pre-programmed auto-dial telephone numbers
- Call termination method (automatic or manual)
- Maximum call duration
- Answering options

All of the above telephones are line-powered telephones and can be connected to any of the following:

- Central Office (CO) line to the Public Switched Telephone Network (PSTN)
- 24 V dc or 48 V dc analog station port of Private Branch Exchange (PBX), Private Automatic Branch Exchange (PABX) or KSU.

Connection may not be made to pay phone extensions or shared service (party) lines.

The phones require a minimum line current of 24 mA to operate. However, when available line current is below 35 mA, depending on the stability of the telephone line, the telephone's operation can be affected. To minimize the effects of lower line current, GAI-Tronics offers a plug-in power supply, Part No. 40404-045.

Standard Operation

Placing an Emergency Call

1. Press the **EMERGENCY** push button to place an immediate call to a preprogrammed emergency number, typically a security office or 911.
2. The emergency operator must press the * key to acknowledge the call.
3. Once acknowledged, the **CALL RECEIVED WHEN LIT** lamp on the phone's front panel illuminates, and communication can begin.

Placing a Non-Emergency Call (Models 294AL-001 and 298-001 Only)

The emergency phone models with keypads can also be used to make non-emergency type calls as follows:

1. Press the **CALL** push button.
2. Wait for dial tone.
3. Use the keypad to dial the desired number.

To disconnect the call, press the **CALL** push button a second time.

Americans with Disabilities Act (ADA) Functionality

Call Received Indicator Lamp

The **CALL RECEIVED WHEN LIT** lamp indicates to hearing-impaired individuals that the emergency call has been answered. When the individual presses the emergency push button, the person receiving the call (typically the security operator) presses the * DTMF button. The telephone detects the * DTMF signal and illuminates the **CALL RECEIVED WHEN LIT** lamp.

Location Identification Code Dialing

The Location Identification Code feature enables security personnel to quickly and easily locate an individual in trouble. When the individual presses the **EMERGENCY** push button, the person receiving the call (typically the security operator) presses the * DTMF button. The telephone detects the * DTMF signal and transmits a three-digit location identification code to identify which emergency telephone is originating the call. This location code can be displayed on a DTMF decoder device (not supplied).



Disconnecting Calls

There are several methods to disconnect emergency telephone calls, including both manual and automatic disconnect methods:

- To remotely disconnect an emergency call, the operator presses the **#** for a least 2 seconds or **##** twice within 2 seconds.
- To manually disconnect an emergency call, press the **EMERGENCY** button after 15 seconds (can be disabled).
- To manually disconnect a non-emergency call, press the **CALL** button a second time.
- To automatically disconnect
 - All calls, loop current disconnect.
 - All calls, maximum call duration timeout (configurable from 1 minute to 99 minutes) or disable to no timeout.
 - Emergency and incoming calls, call progress tones (dial tone, busy signal, fast busy [or reorder] tone)

For factory defaults and available options, please refer to the Programming section of this manual, beginning on page 16.

Installation

 **ATTENTION**  Installation should be performed by qualified personnel and only in accordance with the National Electrical Code or applicable local codes.

Safety Guidelines

When installing any GAI-Tronics telephone equipment, please adhere to the following guidelines to ensure the safety of all personnel:

- Do not install telephone wiring during a lightning storm.
- All telephone models must be properly connected to earth ground to protect personnel and to minimize the effects of any electrostatic discharge (e.g., lightning). The Model 293AL-001, 294AL-001, 297-001, and 298-001 Telephones each include a ground terminal. Please note proper grounding does not eliminate the need for lightning protection for the telephone or the telephone system.
- **Install a UL Listed lightning arrestor** on any phone installed where the phone or phone cable is at risk of being exposed to lightning strikes. The lightning arrestor must be installed as close to the phone as possible to maximize the protection. It must not be installed within the enclosure supplied with the phone. Please consult our Service Center at 800-492-1212 for further information.
- Do not install telephone jacks in wet locations unless the jack is specifically designed for wet locations.
- Do not touch uninsulated telephone wires or terminals unless the telephone line has been disconnected at the network interface.
- The Model 40404-045 Power Supply must be connected to an ac source within 4 feet of the telephone. The ac source and power supply must be mounted in a dry location, such as in a GAI-Tronics stanchion.

General Installation Guidelines

GAI-Tronics emergency phones are designed to operate on telephone lines as detailed in the Product Overview section of this manual. The telephones are designed to operate with one telephone per line. If telephones are operated in parallel or “party line configuration” you may experience sporadic phone operation, difficulties with programming, or premature disconnection of calls. Additionally, if special features, e.g. voice mail, call waiting, etc, are not disabled, the phone may not function.

Tamper-Resistant Hardware

All of the telephones described in this manual are vandal resistant. The front panel for each telephone covered in this manual is attached to its enclosure with tamper-resistant screws. A GAI-Tronics Model 233-001 Tamper-Resistant Screwdriver (sold separately) is recommended for installing the tamper-resistant screws.

Conduit Installation Details

GAI-Tronics recommends installing telephone lines in conduit to protect against accidental damage and vandalism. To prevent moisture from entering the enclosure, we strongly recommend the following:

- Conduit should enter the enclosure from the bottom.
- Sealed fittings should be installed at all cable entry points.
- Silicone sealant or equivalent should be applied around and inside all conduit entries.

Please refer to the examples below for the recommended conduit installation details.

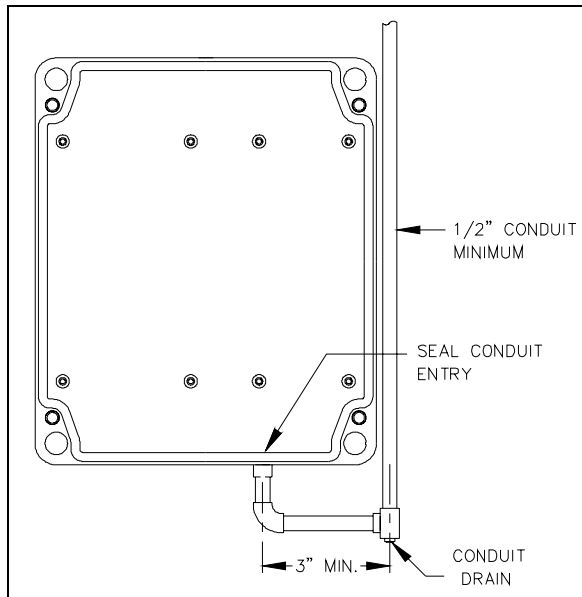

Figure 1. Bottom entry conduit recommended for non-metallic enclosures

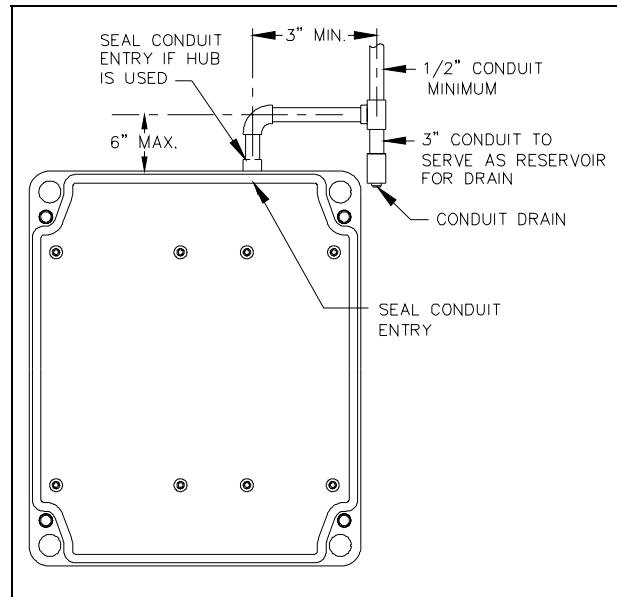

Figure 2. Top entry conduit installation for non-metallic enclosures (NOT recommended)

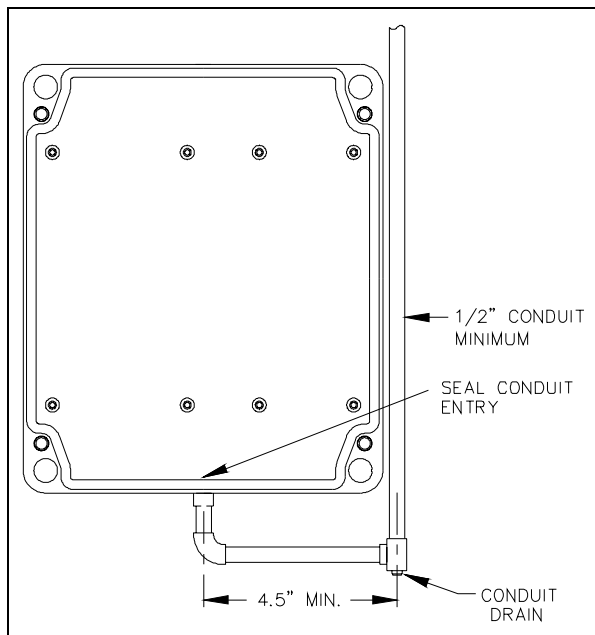

Figure 3. Bottom entry conduit installation details for metallic enclosures

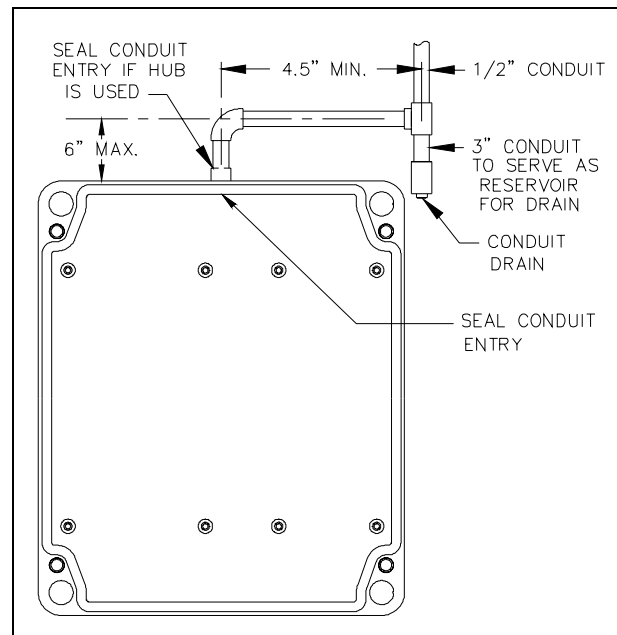

Figure 4. Top entry conduit installation details for metallic enclosures (NOT recommended)

Models 293-001, 293AL-001, and 294AL-001

The mounting and wiring instructions for Models 293-001, 293AL-001 and 294AL-001 are as follows:

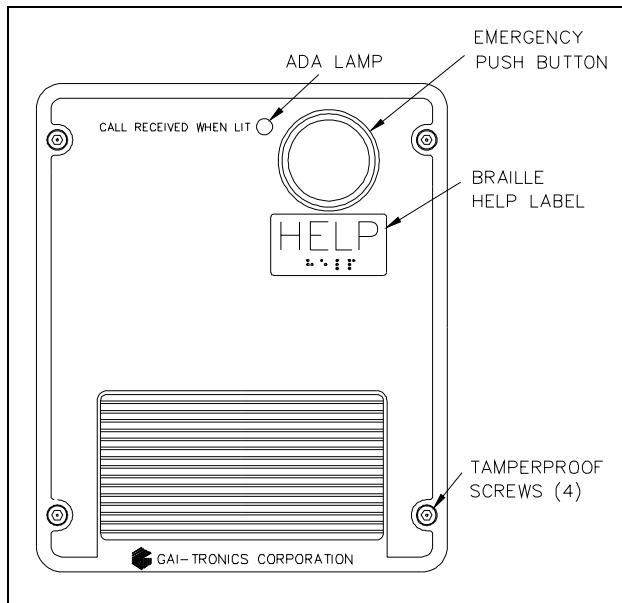

Figure 5. Model 293-001 Emergency Phone in a Non-metallic Enclosure

1. Remove the four tamper-resistant screws from the front panel.
2. Position the enclosure on the mounting surface. The enclosure provides four 0.28-inch mounting holes. Secure it with the four ¼-inch diameter bolts of the appropriate length for the mounting surface.
NOTE: When using the GAI-Tronics Model 231 Pole Mounting Kit, follow the mounting instructions provided in the kit.
3. For Model 293-001 only: Create an access hole using a Greenlee-type punch that is equivalent in size to the conduit diameter. Bottom entry is strongly recommended. Insert a conduit fitting in the access hole. Refer to conduit installation details on page 6.
NOTE: Use silicone sealant or equivalent around and inside all conduit entries.

4. Pull the telephone line through the conduit. Connect the telephone line to the customer-supplied telephone line surge suppressor (if applicable) and modular jack.
5. Connect the telephone's modular plug to a USOC RJ11 or CA11A (Canada) modular jack.
NOTE: A modular jack may be mounted inside the telephone. Telephone line connections directly to TB1 are acceptable.
6. Perform the initial programming of the phone. Refer to the Programming section on page 16.
7. Make hardware configuration changes, if necessary. Refer to page 12 for more information. Verify that the phone is operating properly by calling to and from another phone.
8. Adjust the speaker levels if necessary. See the Audio Level Adjustments section on page 14 for details.
9. Complete the installation by attaching the front panel assembly to the rear enclosure using the four tamper-resistant screws.

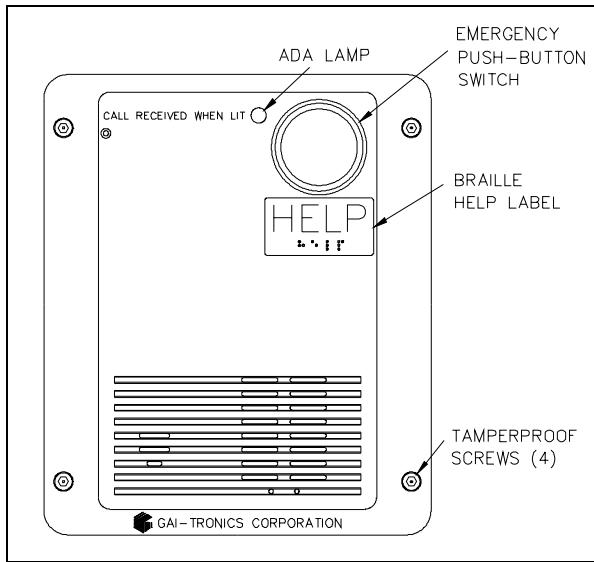

Figure 6. Model 293AL-001

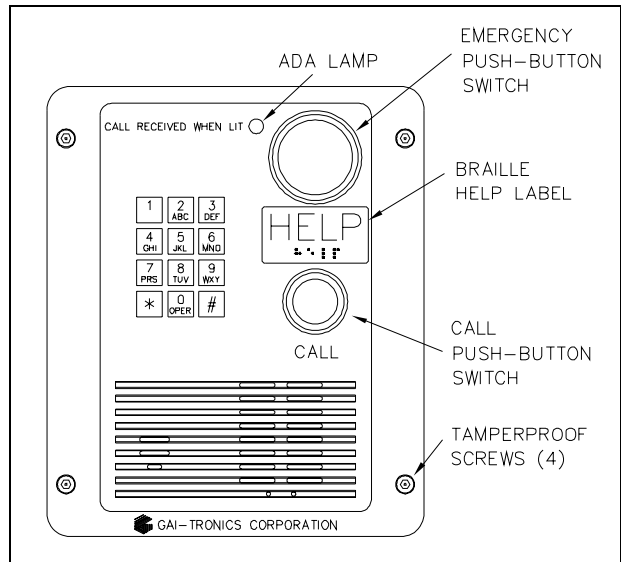

Figure 7. Model 294AL-001

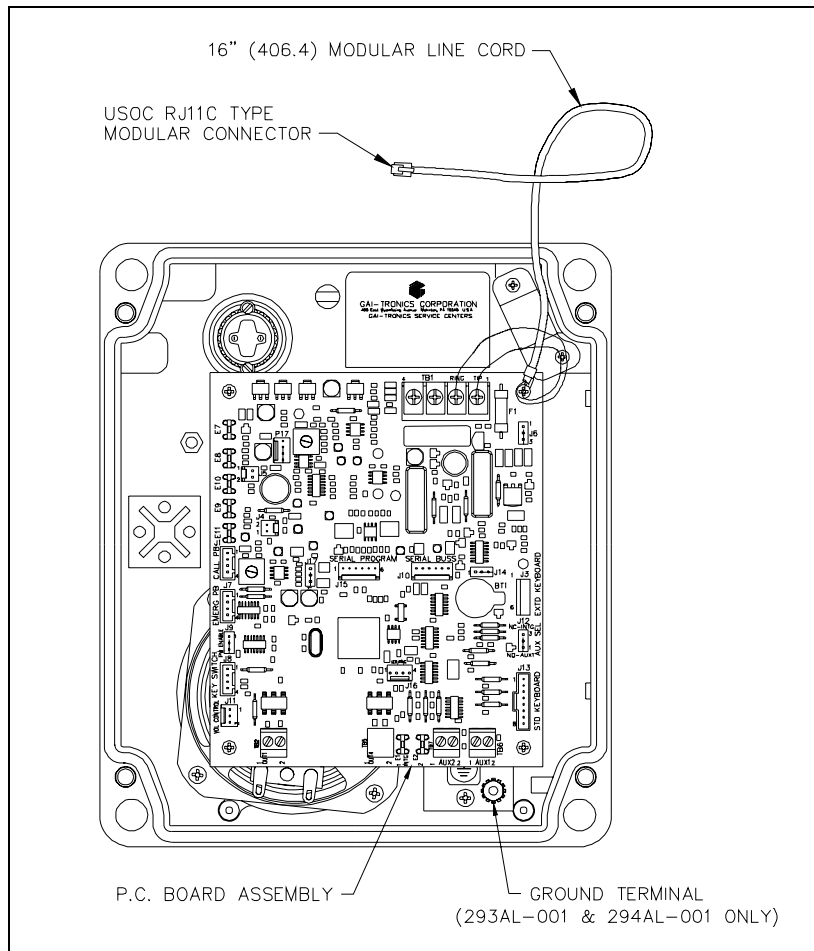

Figure 8. Models 293-001, 293AL-001, and 294AL-001 - Component Locations

Models 297-001 and 298-001

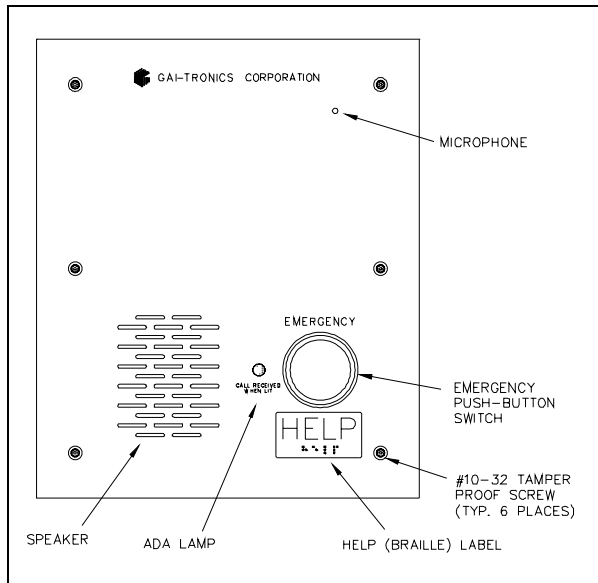

Figure 9. Model 297-001

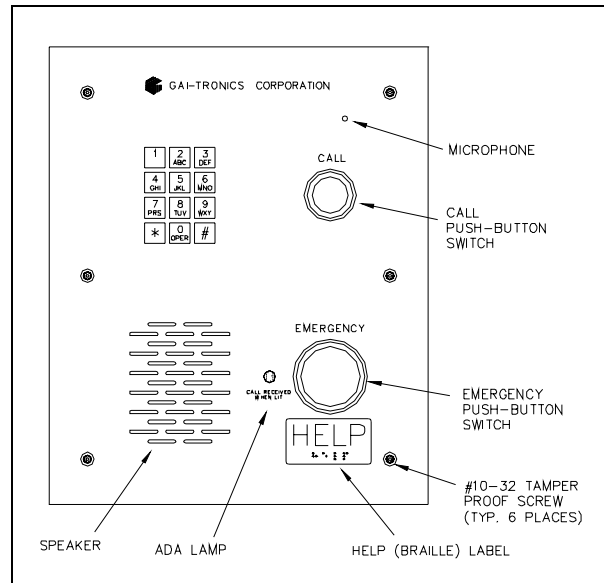

Figure 10. Model 298-001

Stanchion or Flush-mount Applications

1. When mounting in a GAI-Tronics Model 234 Series Stanchion, or for flush-mount installations, the supplied back box must be used to mount the Model 297-001 or 298-001 Telephone. Mount the back box to the structure using the appropriate hardware. Refer to Figure 11 cutout dimensions.
2. If mounted outdoors, the installation of a telephone line suppressor (customer-supplied) on the telephone line is recommended.
3. Remove the tapered plug from the top or bottom cable entry hole in the back box, and install the telephone line and cable fitting.
4. Telephone line connections directly to TB1 are acceptable.
5. If using the modular jack, remove the cover, and connect the red and green wires of the telephone line to the red and green wires of the modular jack. Replace the modular jack cover.
6. Connect the telephone's modular plug to a USOC RJ11 or CA11A (Canada) modular connector or (if applicable) the telephone line suppressor. Refer to Figure 8 for the Model 297-001 and 298-001 component locations.
7. Perform the initial programming of the phone. Refer to the Programming section beginning on page 16.
8. Make hardware configuration changes, if necessary. Refer to page 12. Verify operation by calling to and from another phone.
9. Adjust the speaker levels if necessary. Refer to the Audio Level Adjustments section on page 14.
10. Attach the telephone's front panel to the mounting flanges of the back box using the six supplied #10-32 tamper-resistant screws and washers.

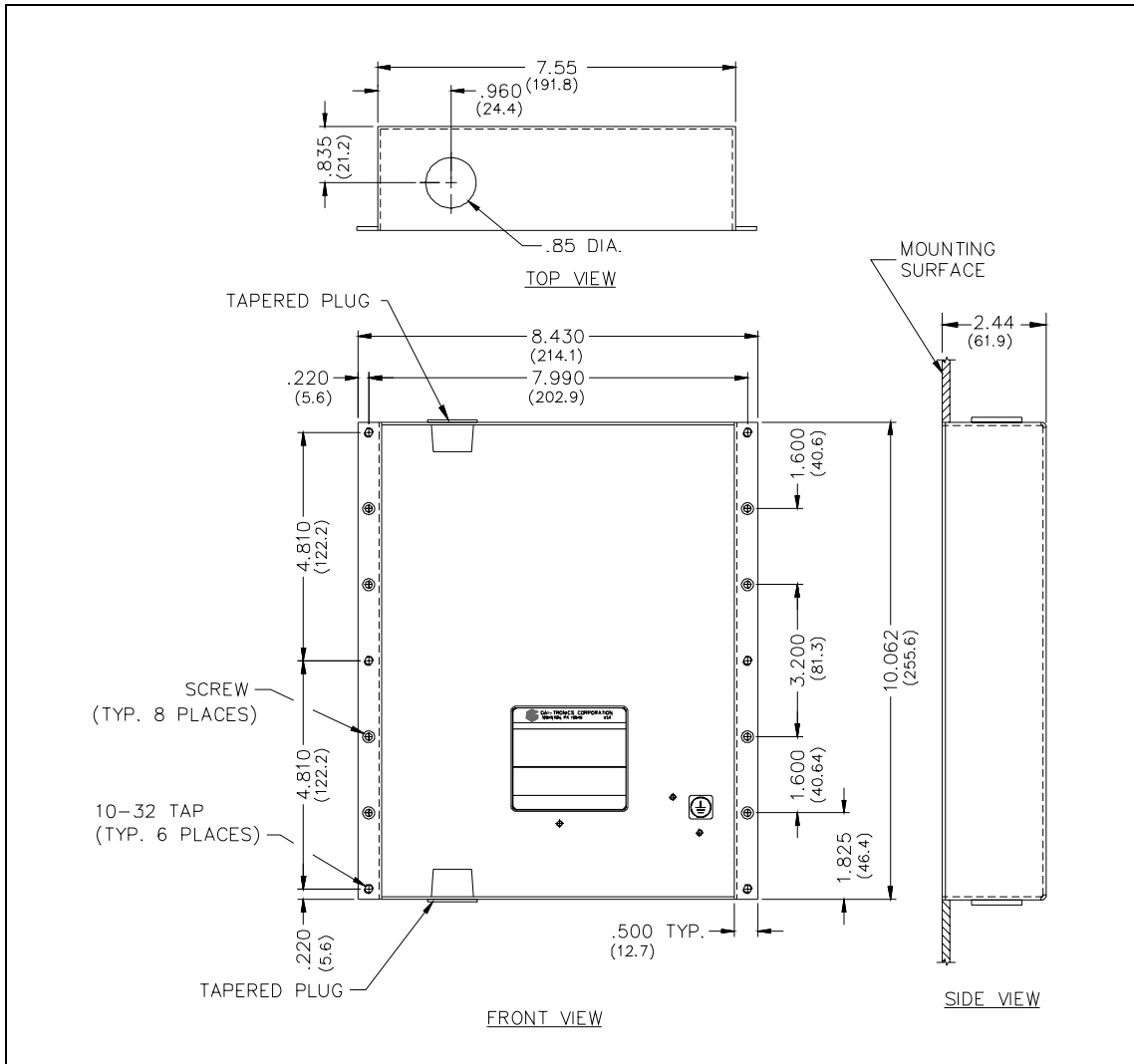

Figure 11. Model 297-001 and 298-001 Mounting Details

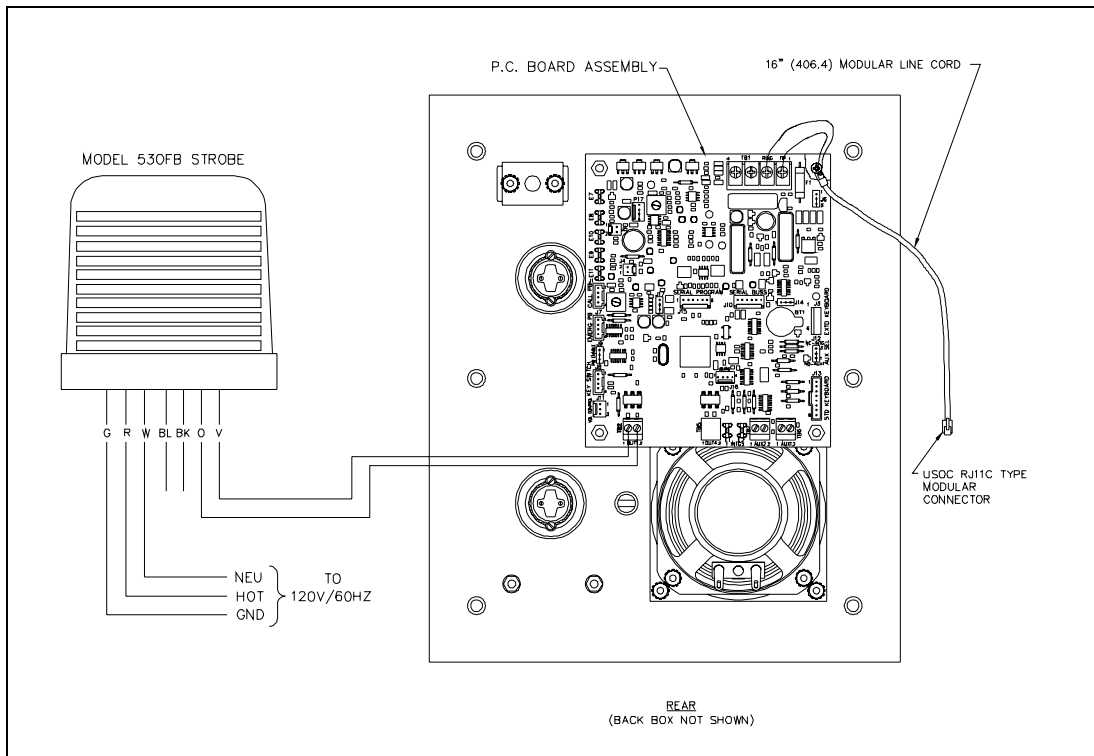

Figure 12. Model 297-001 and 298-001 - Component Locations
(shown with connection to optional GAI-Tronics 530FB/531A Beacon)

Connecting a Beacon

Figure 12 above shows a typical connection detail of the GAI-Tronics 530FB/531A Beacon (sold separately).

Setup

Hardware Configuration

The hardware options are explained in the following sections and the necessary jumper settings are identified to enable or disable each option. We recommend reading the following sections, recording the desired parameters and then making the necessary changes. The *User Settings* column in the Hardware Settings Table on page 24 is provided for you to record your settings. The following options are controlled by specific hardware configurations. See Figure 13 for the jumper locations.

Auto-answer Configuration

Factory Setting: Auto-answer feature enabled

The Auto-answer feature enables or disables the automatic answering of an incoming call. When the Auto-answer feature is enabled, the phone automatically answers the call. When this feature is disabled, the emergency telephone's call button must be pressed to answer the call.

Enable: Insert the J14 jumper on pins 2 and 3.

Disable: Insert the J14 jumper on pins 1 and 2. (Do not use this setting except under the direction of GAI-Tronics personnel.)

NOTE: The Auto-answer feature must be enabled during remote programming.

Polarity Configuration

Factory Setting: Non-polarity sensitive

This telephone can be configured to be polarity or non-polarity sensitive. When using the non-polarized setting, the telephone operates with the telephone line's positive terminal connected to either the tip or the ring. When using the polarized setting, the telephone only operates with the telephone line's positive terminal connected to the tip. Use the Polarity Sensitive setting to allow a line voltage reversal disconnect signal to disconnect the call.

Non-polarity Sensitive: Insert the J6 jumper on pins 2 and 3.

Polarity Sensitive: Insert the J6 jumper on pins 1 and 2.

Password Enable/Disable Configuration

Factory Setting: Enabled

This telephone can be configured to enable or disable the password protection for programming. This can be useful when initially programming the telephones. Please see the Programming section of this manual.

Password Enabled: Insert a jumper on pins 2 and 3 of J9.

Password Disabled: Insert a jumper on pins 1 and 2 of J9.

Auxiliary Output

Each telephone includes one isolated solid state switch capable of switching a maximum of 48 V dc, 125 mA or 28 V_{RMS} ac, 80_{RMS} mA. TB2 (OUT1) on the emergency phone PCBA provides the connections for the auxiliary output. Refer to Figure 13 for the location of TB2.

The auxiliary output allows peripheral equipment, such as beacons, video cameras, and alarm generators, to be activated when the EMERGENCY push button is pressed. The relay remains energized for the duration of the emergency call.

In many applications, the auxiliary output is used to operate a GAI-Tronics Model 530FB/531A Beacon (sold separately). For connection details, please refer to the Model 530FB/531A installation instructions included with the beacon. Information is also available at www.gai-tronics.com.

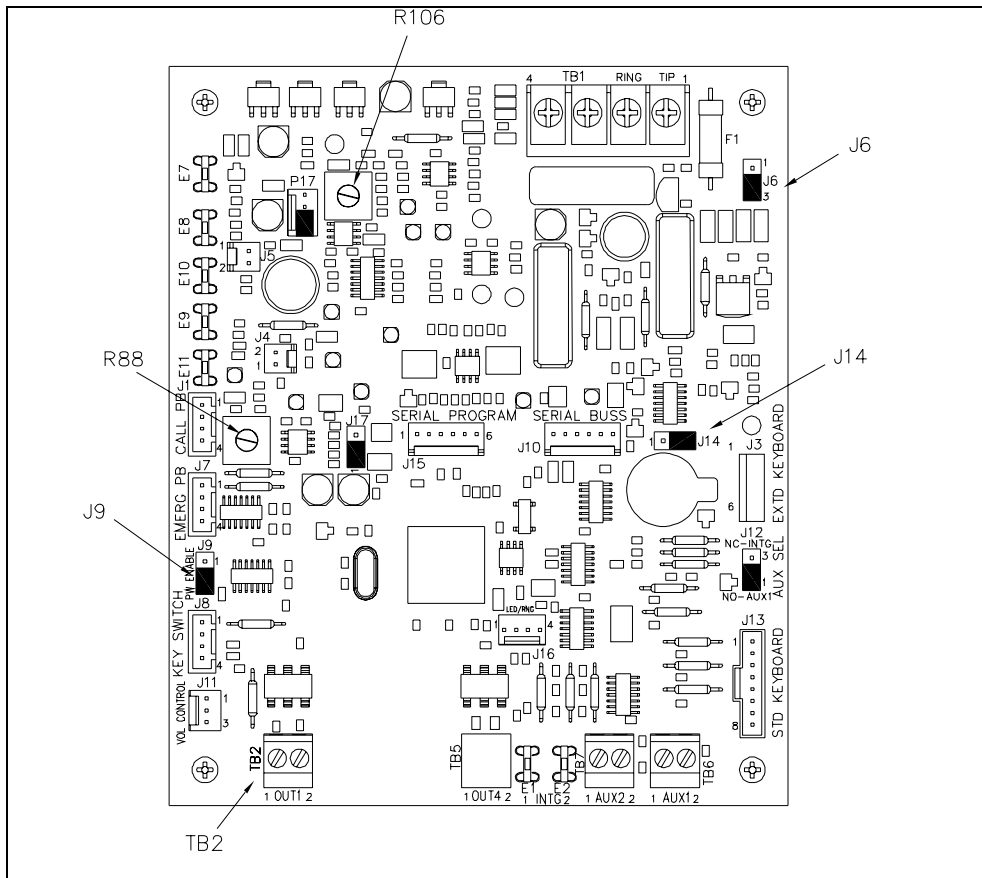

Figure 13. Emergency Phone PCBA

Audio Level Adjustments

Speaker Volume Adjustments

The speaker volume and microphone sensitivity are factory set to nominal levels that are acceptable for most installations. However, some installations may require adjustments for the speaker and microphone. Both the speaker and microphone adjustments are made using potentiometers on the emergency phone PCBA. R106 is the speaker volume adjustment, and R88 is the microphone sensitivity adjustment. Please refer to Figure 13 for the potentiometer locations.

After making any adjustments to the audio levels, perform the automatic line level compensation as detailed below.

When the phones leave the factory, the microphone potentiometer is set near minimum, and the speaker pot is set to maximum. The speaker volume potentiometer (R106) provides a 6-dB range of adjustment and the microphone sensitivity potentiometer (R88) provides a 12-dB range of adjustment.

Special care must be given to adjusting the speaker volume and microphone level. If one or both of the levels are set too high, acoustic feedback (howling) can occur. If acoustic feedback occurs, we recommend returning both potentiometers to the nominal factory settings and beginning the adjustment again from this point.

Additionally, the acoustical characteristics of the emergency phone with the front panel removed are different than when the front panel is tightly mounted in the enclosure. After making any volume adjustments, we recommend mounting the front panel to the enclosure and testing the phone again.

Automatic Line Level Compensation for Optimum Audio Performance

Every telephone line has different audio and electrical characteristics. To accommodate the varying lines, the telephone has an automatic line level compensation function. When a telephone is first installed and connected to a telephone line, we recommend resetting the automatic level compensation feature. The automatic line level compensation feature is reset remotely (See the Remote Programming Section of this manual) or locally with the **#2316** command, as follows:

For single button emergency phones:

1. Remove the phone from the back box or enclosure.
2. Disconnect the EMERGENCY push button from J7, the “Emerg PB” socket on the phone PCBA.
3. Connect the EMERGENCY push button to J1, the “Call PB” socket on the phone PCBA.
4. On the PCBA, enable auto-answer by placing a jumper between pins 2 and 3 on J14 and disable password protection by removing the jumper from J9.
5. Connect a keypad to J13. (Keypad, Part No. 51035-011, and Keypad Cable Assembly, Part No. 61504-048 are sold separately).
6. Press the EMERGENCY button. After you hear the dial tone, simultaneously press the **1** and **#** keys. After a confirmation tone is heard, enter the command **#2316**. To hang up the phone, press the EMERGENCY button or wait for the phone to time out.
7. Press the EMERGENCY push button.
When dial tone is steady (with no volume variations), the process is complete. Depending on the phone line and the duration dial tone, it may be necessary to repeat this step one or more times.

8. Disconnect the EMERGENCY push button from J1, the “Call PB” socket on the phone PCBA.
9. Reconnect the EMERGENCY push button to J7, the “Emerg PB” socket on the phone PCBA.
10. Configure the phone for auto-answer and password protection as required. Please see the Programming section of this manual beginning on page 16.
11. Disconnect the keypad from J13.
12. Install the phone in the back box or enclosure.

For emergency phones with a CALL push button and keypad:

Disable password protection by removing the jumper from J9.

1. Press the CALL button. After you hear the dial tone, simultaneously press the **1** and **#** keys. After you hear the confirmation tone, enter the command **#2316**. To hang up the phone, press the CALL button or wait for the phone to time out.
2. Press the CALL push button.
When the dial tone is steady (with no volume variations), the process is complete. Depending on the phone line and the duration of dial tone, it may be necessary to repeat this step one or more times.

Programming

The telephone can be programmed remotely from another telephone, or locally at the emergency telephone. To program the Model 294AL-001 and Model 298-001 locally, the front panel keypad can be used. However, to program the Models 293-001, 293AL-001, and 297-001 locally, a Model 51035-011 Keypad must be connected to J13 on the telephone PCBA using the Model 51504-048 Keypad Cable Assembly. Refer to Figure 8 for locations. Refer to the Local Programming section on page 17.

For remote programming, a touch-tone (DTMF) telephone connected to a separate central office (CO) or private branch exchange (PBX) line is required. See the Remote Programming section below.

Remote Programming

The programming mode is accessed by dialing a four-digit programming password. Should it become necessary to bypass the password protection feature, see the Password Disabled Programming section on page 17.

Password Enabled Programming

1. Enable the password protection feature—insert the J9 jumper on pins 2 and 3.
2. Enable the auto-answer feature—insert the J14 jumper on pins 2 and 3.
3. Using a touch-tone telephone, call the emergency telephone. The emergency telephone automatically answers the call and generates a splash tone followed by a success tone (single beep).
4. Dial the four-digit password. If the password has not been altered, dial **2468** (factory setting). Otherwise, dial the preprogrammed user password. A success tone (single beep) is generated to indicate the programming mode has been accessed.

NOTES:

- The telephone automatically times out if 20 seconds elapse between digit entries, or if an invalid password is entered.
 - If DTMF digits have not been dialed within three seconds of the call initiation, the telephone remains off-hook and the programming mode is terminated.
 - If the success tone is not generated, the telephone has failed to recognize the password. Therefore, the telephone must then be programmed with the password disabled. See the Password Disabled Programming section on page 17.
5. After you hear the success tone, begin entering the desired user-programmable parameters. Refer to the Programming Sequences section on page 19. A success tone (single beep) is generated each time a new parameter is accepted. An error tone (two beeps) is generated to indicate an error. If an error tone is generated, verify the programming sequence, and enter the sequence again.
 6. Terminate the programming by placing the touch-tone telephone on-hook.

Password Disabled Programming

1. Disable the password protection feature—insert the J9 jumper on pins 1 and 2.
2. Enable the auto-answer feature—insert the J14 jumper on pins 2 and 3.
3. Using the touch-tone telephone, call the emergency telephone. The emergency telephone automatically answers the call and generates a splash tone followed by a success tone (single beep).
4. Begin entering the desired programmable parameters. See the Programming Sequences section on page 19. A success tone (single beep) is generated each time a new parameter is accepted. An error tone (two beeps) is generated to indicate an error. If an error tone is generated, verify the programming sequence, and enter the sequence again.

NOTE: The telephone automatically times out if 20 seconds elapse between digit entries.

5. Terminate the programming by placing the touch-tone telephone on-hook.

Local Programming

For Models 293-001, 293AL-001, and 297-001, the procedure is as follows:

1. Connect keypad to connector J13. See Figure 8 and Figure 12 for details. Contact GAI-Tronics Field Service Department for details.
2. Temporarily move the EMERGENCY push-button switch harness from connector J7 to the CALL push-button connector J1.
3. Disable the password protection feature—insert the J9 jumper on pins 2 and 1.
4. Press the EMERGENCY push button. A dial tone is broadcast over the speaker. Simultaneously press **1** and **#** on the keypad. The telephone generates a splash tone followed by a success tone.
5. Enter the desired programmable parameters. See the Programming Sequences section below.

A success tone (single tone [DTMF #]) tone is generated each time a new parameter is accepted. An error tone (double beep) is generated to indicate an error. If an error tone is generated, verify the programming sequence is correct, and enter the sequence again.

NOTES:

- The telephone is off-hook during local programming. Therefore, programming should be completed quickly to avoid any off-hook timeouts controlled by the CO or PBX.
 - The telephone will automatically time out if 20 seconds elapse between digit entries.
6. Terminate the programming by pressing the EMERGENCY push button.
 7. Disconnect the keypad from connector J13.
 8. Return the EMERGENCY push-button switch to connector J7.
 9. Enable the password protection feature—insert the J9 jumper on pins 3 and 2.

For Models 294AL-001, and 298-001, the procedure is as follows:

1. Disable the password protection feature—insert the **J9** jumper on pins 2 and 1.
2. Press the **CALL** push button. A dial tone is broadcast over the speaker. Simultaneously press **1** and **#** on the phone keypad. The telephone generates a splash tone followed by a success tone.
3. Enter the desired programmable parameters. See the Programming Sequences section below.

A success tone (single tone [DTMF #]) tone is generated each time a new parameter is accepted. An error tone (double beep) is generated to indicate an error. If an error tone is generated, verify the programming sequence is correct, and enter the sequence again.

NOTES:

- The telephone is off-hook during local programming. Therefore, programming should be completed quickly to avoid any off-hook timeouts controlled by the CO or PBX.
 - The telephone will automatically time out if 20 seconds elapse between digit entries.
4. Terminate the programming by pressing the **CALL** push button.
 5. Enable the password protection feature—insert the **J9** jumper on pins 3 and 2.

Programming Sequences

The programming information on the following pages explains the programming options. The telephone is shipped from the factory with a set of default parameters that are listed in the Programming Table on page 24. A User Settings section has been provided in the Programming Table for the user to record the selected programming parameters.

Programming Key

D = digit 0-9, *, or #
N = digit 0-9
L = 0 - Disable, 1 - Enable
T = 0-350 ms, 1-50 ms, 2-25 ms

It is recommended that the user read the sections that follow, record the desired parameters in the User Settings section of the Programming Table, and then complete the programming using the instructions from either the Remote Programming or the Local Programming section.

Dialing Options

The emergency telephones can be configured for either auto-dialing or ring-down operation. Select the dialing option that fits your application. The dialing options are explained in detail in the following sections.

Auto-dialing

The EMERGENCY push button can be programmed to call three unique telephone numbers. The unique telephone numbers include a primary telephone number and two backup, or roll over, numbers. In the event an emergency call cannot connect to the primary telephone number (i.e., a busy signal or no answer), the emergency phone will automatically dial the first backup, or roll over, number. Again, in the event an emergency call cannot connect to first back-up telephone number, the emergency phone will automatically dial the second backup, or roll over, number. This sequence will continue until the emergency call is answered, or the sequence is repeated three times for a total of 12 call attempts.

For the rollover feature to function properly, all three auto-dial memories must be programmed with valid telephone numbers. The three auto-dial numbers can be the same or any combination of phone numbers. If the phone is programmed with only one or two auto-dial numbers, the rollover operation will not function and the numbers will only be dialed one time.

If an emergency phone is connected to a PBX, PABX, KSU, etc., telephone system, the emergency phone can be programmed to access outside CO lines. Typically access to a CO line requires adding a digit (e.g. 9) to the auto-dial number. Also, a “pause” may be required in the auto-dial number. The pause typically is required to wait for secondary (CO line) dial tone. See the example in the Emergency Button Auto-dial Number 1 in the table below.

In addition to the pause, the emergency telephone has a programmable Primary Dial Tone Delay and Secondary Dial Tone Delay. Both delays determine the amount of time the emergency phone will wait before dialing the stored telephone number. The Secondary Dial Tone Delay can only be used if a “9” is dialed to gain access to a CO line.

Ring-down Operation

Ring-down operation enables the telephone to go off-hook when the EMERGENCY push button is pressed. The ring-down system must detect loop current and ring-down to the appropriate telephone.

| Feature | Key Sequence | Description | Default |
|-------------------------------------|--------------|--|----------------------|
| Emergency Button Auto-dial Number 1 | DD ... *1 | <p>Assigns a telephone number to the auto-dial memory 1. DD ... represents the telephone number, which can be up to 20 digits in length.</p> <p>For access to an outside line, a pause may be required in the telephone number to wait for secondary dial tone. The # represents a pause in the telephone number.</p> <p><i>Examples:</i></p> <p>To assign the police emergency number 911 to the auto-dial button, enter 911*1.</p> <p>To assign 911 when a “9” is required to gain access to a CO line, enter 9*#911*1.</p> <p>To store * or # as part of the auto-dial number, (such as for speed dialing), enter these digits twice in succession.</p> | *123456789*0# |
| Emergency Button Auto-dial Number 2 | DD ... *2 | Same as Emergency Button Auto-dial Number 1 except the sequence ends in *2 instead of *1. | None |
| Emergency Button Auto-dial Number 3 | DD ... *3 | Same as Emergency Button Auto-dial Number 1 except the sequence ends in *3 instead of *1. | None |
| Call Button Auto-dial | DD ... *4 | Same as Emergency Button Auto-dial Number 1 except the sequence ends in *4 instead of *1. | None |
| Primary Dial Tone Delay | # 1 0 NN | <p>The dial tone delay is the amount of time the unit waits for a dial tone before auto-dialing the telephone number. (00 [infinite]; 01-15 seconds)</p> <p><i>Example:</i> To wait five seconds for a dial tone, enter # 1 0 0 5.</p> | 00 (Infinite) |
| Secondary Dial Tone Delay | # 1 1 NN | <p>This feature is only used if you must dial 9 to access an outside line. It determines the amount of time (00-15 seconds) the telephone waits for a second dial tone. The first programming step indicated you must program 9*# and the number you want the auto-dial to access. This programming parameter allows you to choose the amount of time the telephone waits after encountering # before dialing the auto-dial number.</p> <p><i>Example:</i> To wait ten seconds for the second dial tone, enter # 1 1 1 0.</p> | 00 (0 seconds) |
| Ring-down Operation | *1 | This option clears the telephone number to prevent auto-dialing when the button is pressed. Once the button is pressed, the ring-down system must detect loop current and ring-down to the appropriate telephone. | None |

Password

The Password Protection feature allows you to change the four-digit password required to remotely program the emergency telephone. Each telephone is password protected to maintain the integrity of programmed information and should not be disabled.

The password is required to enter the programming mode when programming the telephone from a remote location. The programming password hardware configuration must be enabled when programming with the password. To enable the Password Protection feature, insert the J9 jumper on pins 2 and 3. Complete the key sequence to change the four-digit password.

| Feature | Key Sequence | Description | Default |
|---------------------|---------------|--|---------|
| Password Protection | # 1 4 N N N N | A four-digit password must be supplied to remotely program the telephone. If you change the password and cannot enter programming mode, see the Password Disabled Programming section. <i>Example:</i> To program the password 1234, enter # 1 4 1 2 3 4 . | 2468 |

Silent Monitoring Feature

When the Silent Monitoring feature is enabled, the splash tone is eliminated, and silent monitoring can begin without notifying individuals near the telephone.

| Feature | Key Sequence | Description | Default |
|-------------------|--------------|--|-----------------|
| Silent Monitoring | # 1 6 L | Enabling the Silent Monitoring feature allows a person to call the emergency telephone and monitor the area around the telephone without sounding a splash tone. To enable the Silent Monitoring feature (disable splash tone), L=1. To disable the Silent Monitoring feature (enable splash tone), L=0. | 0 (Disabled) |



Off-Hook Ringing

The emergency phone can generate a ringing signal from the speaker when the phone is called. As a factory default, this feature is disabled.

| Feature | Key Sequence | Description | Default |
|----------|--------------|---|-----------------|
| Ringling | # 2 2 L | Enabling the Off-Hook Ringing feature allows a person to call the phone and have the phone function as a normal telephone. The phone will ring after the splash tone is heard in the receiver if remote programming is not commenced within 7 seconds of the splash tone. To enable the ringing feature (enable splash tone and ringing), L=1. To disable the ringing feature (only splash tone on the phone), L=0 NOTE: Only Model 294AL-001 and 298-001 Phones can be answered when they are ringing by pressing the Call button. | 0 (Disabled) |

Disconnect Options

Several options are available for disconnecting a call. Any combination of disconnect options may be used. Select the method that best suits the application, and follow the appropriate programming directions.

| Feature | Key Sequence | Description | Default |
|---|--------------|--|-----------------|
| Emergency Push-button Disconnect Option | # 1 7 L | <p>The EMERGENCY button cannot be used to disconnect a call for 10 seconds after initially pressing the push button. However, the emergency push button can be used to disconnect calls after the ten-second push button lockout period elapses when $L=1$. To prevent the EMERGENCY push button from disconnecting the call, set $L=0$.</p> <p><i>Example:</i> To enable the EMERGENCY push button disconnect, enter # 1 7 1. To disable the EMERGENCY push button disconnect, enter # 1 7 0.</p> | 1 (Enabled) |
| Call Time-out Disconnect Option | # 1 2 N N | <p>This feature programs the maximum length of a call if no other disconnect features are used. The valid entries are 1-99, representing 1 minute increments and 0 representing 4.5 hours (infinite). The call duration timer begins when the emergency telephone goes off-hook. The emergency telephone automatically disconnects after the programmed time-out period elapses.</p> <p>The user can immediately press the EMERGENCY button to reconnect the autodial number. This feature helps prevent non-emergency calls from tying up emergency lines for long lengths of time.</p> <p><i>Example:</i> To make the maximum call length two minutes, enter # 1 2 0 2.</p> | 10 (10 minutes) |
| Dial Tone Disconnect Option | # 1 9 L | <p> WARNING </p> <p>Use this option only if no other disconnect options are available.</p> <p>If this option is enabled, the telephone automatically terminates a call if it detects a dial tone continuously for 10 seconds, such as if the called party hangs up. To enable the dial tone disconnect, $L=1$. To disable the dial tone disconnect, $L=0$.</p> <p><i>Example:</i> To enable the dial tone disconnect, enter # 1 9 1. To disable the dial tone disconnect, enter # 1 9 0.</p> | 0 (Disabled) |

Americans with Disabilities Act (ADA) Programming

The ADA features provide the following benefits:

- **CALL RECEIVED WHEN LIT** indication - This lamp provides indication to hearing-impaired individuals that the emergency call has been answered.
- **The Location Identification Code** - This feature enables security personnel to quickly and easily locate an individual in trouble.
- **DTMF Call Disconnect** - Enables the security operator to disconnect the call by pressing ##.

| Feature | Key Sequence | Description | Default |
|----------------------------------|---------------|---|---|
| ADA Options | # 1 8 L | This option enables these features: call received indicator lamp activation, location identification code dialing, and the DTMF disconnect feature. To enable the ADA options, set $L=1$. To disable the ADA options, set $L=0$. | 1 (Enabled) |
| Location Identification ID Setup | # 1 3 L N N N | This option enables and stores the three-digit location identification ID number. To enable the ID feature, set $L=1$. To disable the ID feature, $L=0$. Enter the three-digit location identification code in the sequence $N N N$. <i>For Example:</i> To enable the location ID feature and store the three-digit ID code 357, enter # 1 3 1 3 5 7 . To disable the location ID feature, enter # 1 3 0 0 0 . NOTE: The ADA options must also be enabled. | No default setting. The user must complete this step to have the identification code transmitted. |

Automatic Line Level Compensation for Optimum Audio Performance

Every telephone line has different audio and electrical characteristics. To accommodate the varying lines, the telephone has an automatic line level compensation function. When a telephone is first installed and connected to a telephone line, we recommend initiating the automatic level compensation feature. The automatic line level compensation is reset with the **#2316** command.

| Feature | Key Sequence | Description | Default |
|---|--------------|---|---------|
| Reset Automatic Line Level Compensation | # 2316 | This sequence resets the automatic line level compensation feature. See page 14 for details on initiating the compensation process. | None |

| Hardware Settings Table | | | | |
|-------------------------|------------------|-----------------|---------------|-----------------|
| Function | Default Settings | | User Settings | |
| | Setting | Jumper/Position | Setting | Jumper/Position |
| Auto-answer | Enabled | J14/3 & 2 | | |
| Password Protection | Enabled | J9/3 & 2 | | |
| Line Polarity | Non-polarized | J6/3 & 2 | | |

| Programming Table | | | | |
|-------------------------------------|----------------|--------------------------------|---------------|--|
| Function | Key Sequence | Default Settings | User Settings | |
| Auto-dial Programming | | | | |
| Emergency Button Auto-dial Number 1 | <i>DD*1</i> | <i>*123456789*0#</i> | | |
| Emergency Button Auto-dial Number 2 | <i>DD*2</i> | None | | |
| Emergency Button Auto-dial Number 3 | <i>DD*3</i> | None | | |
| Call Button Auto-dial Number | <i>DD*4</i> | None | | |
| Primary Dial Tone Delay | <i>#10NN</i> | Infinite | | |
| Secondary Line Dial Tone Delay | <i>#11NN</i> | 0 (zero) seconds | | |
| Ring-down Operation | <i>*1</i> | None | | |
| Password Programming | | | | |
| Password Protection | <i>#14NNNN</i> | 2468 | | |
| Disconnect Programming | | | | |
| Emergency Push-button Disconnect | <i>#17L</i> | 01 (enabled) | | |
| Call Time-out Disconnect | <i>#12NN</i> | 10 minutes | | |
| Dial Tone Disconnect | <i>#19L</i> | 0 (disabled) | | |
| Other Programming Features | | | | |
| Silent Monitoring | <i>#16L</i> | 0 (disabled) | | |
| Ringing | <i>#22L</i> | 0 (disabled) | | |
| ADA Programming | | | | |
| ADA Options Enable | <i>#18L</i> | <i>#181</i> | | |
| Identification Code Entry | <i>#13LNNN</i> | None | | |
| Table Key | | | | |
| D = digit 0-9, *, or # | | N = digit 0-9 | | |
| L = 0-Disable, 1-Enable | | T = 0-350 ms, 1-50 ms, 2-25 ms | | |

Maintenance

If your GAI-Tronics Phone requires service, contact your GAI-Tronics Regional Service Center for a return authorization number (RA#). Equipment should be shipped prepaid to GAI-Tronics with a return authorization number and a purchase order number. If the equipment is under warranty, repairs will be made without charge. Please include a written explanation of all defects to assist our technicians in their troubleshooting efforts.

Call 800-492-1212 inside the USA or 610-777-1374 outside the USA for help identifying the Regional Service Center closest to you.

Specifications

| | |
|--|---|
| Auto-dial digit limit | 24 digits |
| Electrical | |
| Audio output | Voice - 80 dB SPL @ 1 meter with 40 mA loop current 1 kHz tone - 76 dB SPL @ 1 meter with 40 mA loop current |
| Input | 24 V dc or 48 V dc |
| Phone line requirements | Loop start, central office (CO), or Analog station port (PBX, PABX, or KSU) |
| Minimum loop current..... | 24 mA (35 mA recommended) |
| Auxiliary output (Isolated solid state switch) | 48 V dc @ 125 mA 28 V _{RMS} ac @ 80 mA _{RMS} |
| Signaling..... | DTMF 100 ms tone |
| Memory | Non-volatile EEPROM |
| Mechanical | |
| Operating temperature range..... | -40° C to +60° C |
| Relative humidity | to 95%, no condensation |
| PCBA (printed circuit board assembly)..... | Conformal coated |

Model 293-001

| | |
|------------------------------|---|
| Enclosure construction | Valox (high impact, glass-reinforced polyester) painted safety yellow |
| Dimensions | 9.5 H × 8 W × 4 D inches (241.3 × 203.2 × 101.6 mm) |
| Weight | 4.0 lbs. |

Model 293AL-001 and 294AL-001

| | |
|--|---|
| Enclosure construction | Cast aluminum painted safety yellow |
| (Model 294AL-001 only) Braille dial pad..... | Chrome-plated zinc |
| Dimensions | 9.5 H × 8 W × 4 D inches (241.3 × 203.2 × 101.6 mm) |
| Weight | |
| Model 293AL-001..... | 7.8 lbs. |
| Model 294AL-001..... | 8.5 lbs. |

Model 297-001 and 298-001

| | |
|---|---|
| Construction | |
| Panel..... | 14-gauge, brushed stainless steel |
| Back box..... | 16-gauge cold-rolled steel with black polyurethane finish |
| (Model 298-001 only) Braille dial pad..... | Chrome-plated zinc |
| Dimensions | |
| Panel..... | 12.0 H × 10.0 W inches (304.8 × 254 mm) |
| Back box (depth from mounting surface)..... | 2.38 inches (60.5 mm) |
| Panel Cutout | 10.1 H × 8.43 W inches (255.57 × 214.12 mm) |
| Weight | |
| Model 297-001..... | 6.5 lbs. |
| Model 298-001..... | 7.2 lbs. |

Approvals

Safety of Information Technology Equipment..... UL/CSA 60950

Enclosures for Electrical Equipment UL 50, Type 3R

47 CFR Part 68

Certification Number US: ADGTE04B0414HAC

Ringer Equivalence Number4B

Network connection (USOC)..... RJ11

IC Information (Canada)

IC Certification Number 882B-GTC S.M.A.R.T.

Ringer Equivalence Number4B

Connection Method CA11A

Replacement Parts

| Part No. | Description | 293 -001 | 293AL -001 | 294AL -001 | 297 -001 | 298 -001 |
|-----------|---|-------------|---------------|---------------|-------------|-------------|
| 233-001 | Model 233-001 Tamper-Resistant Screwdriver | ■ | ■ | ■ | ■ | ■ |
| 12562-102 | Emergency PCBA Replacement Kit (Standard) | ■ | ■ | ■ | ■ | ■ |
| 51035-005 | PCBA, Keypad, metallic | | | ■ | | ■ |
| 28299-007 | Tamperproof Screws (Flush-mount models) | | | | ■ | ■ |
| 28229-004 | Tamperproof Screws, 1-1/8 inch | ■ | ■ | ■ | | |
| 12520-006 | Push Button Replacement Kit (1.5-inch, red) | ■ | ■ | ■ | ■ | ■ |
| 12520-007 | Push Button Replacement Kit Black | | | ■ | | ■ |
| 40404-045 | Plug-in Power Supply | ■ | ■ | ■ | ■ | ■ |
| 12521-001 | Microphone Replacement Kit | ■ | ■ | ■ | ■ | ■ |
| 12522-003 | Speaker Replacement Kit | ■ | ■ | ■ | ■ | ■ |
| 51035-011 | Keypad, plastic (also used for local programming) | ■ | ■ | | ■ | |
| 61504-048 | Keypad Cable Assembly (also used for local programming) | ■ | ■ | ■ | ■ | ■ |

User Instructions (USA)

This equipment complies with Part 68 of the FCC rules and the requirements adopted by the ACTA. On this equipment is a label that contains, among other information, a product identifier in the format US:AAAEQ##TXXXX. If requested, this number must be provided to the telephone company.

A plug and jack used to connect this equipment to the premises wiring and telephone network must comply with the applicable FCC Part 68 rules and requirements adopted by the ACTA. A compliant telephone cord and modular plug is provided with this product. It is designed to be connected to a compatible modular jack that is also compliant. See installation instructions for details.

The REN is used to determine the number of devices that may be connected to a telephone line. Excessive RENs on the telephone line may result in the devices not ringing in response to an incoming call. In most but not all areas, the sum of the RENs should not exceed five (5.0). To be certain of the number of devices that may be connected to a line, as determined by the total RENs, contact the local telephone company. For products approved after July 23, 2001, the REN for this product is part of the product identifier that has the format US:AAAEQ##TXXXX. The digits represented by ## are the REN without a decimal point (e.g., 03 is an REN of 0.3). For earlier products, the REN is separately shown on the label.

If this equipment [GAI-Tronics telephone] causes harm to the telephone network, the telephone company will notify you in advance that temporary discontinuance of service may be required. But if advance notice isn't practical, the telephone company will notify the customer as soon as possible. Also, you will be advised of your right to file a complaint with the FCC if you believe it is necessary.

The telephone company may make changes in its facilities, equipment, operations, or procedures that could affect the operation of the equipment. If this happens the telephone company will provide advance notice in order for you to make necessary modifications to maintain uninterrupted service.

If trouble is experienced with this equipment [GAI-Tronics telephone], for repair or warranty information, please contact GAI-Tronics Corporation at 800-492-1212 or www.gai-tronics.com. If the equipment is causing harm to the telephone network, the telephone company may request that you disconnect the equipment until the problem is resolved.

Connection to party line service is subject to state tariffs. Contact the state public utility commission, public service commission or corporation commission for information.

User Instructions (Canada) CP-01, Issue 8, Part I: Section 14.1

NOTICE: The Industry Canada label identifies certified equipment. This certification means that the equipment meets certain telecommunications network protective, operational and safety requirements as prescribed in the appropriate Terminal Equipment Technical Requirements document (s). The Department does not guarantee the equipment will operate to the user's satisfaction. Before installing this equipment, users should ensure that it is permissible to be connected to the facilities of the local telecommunications company. The equipment must also be installed using an acceptable method of connection. The customer should be aware that compliance with the above conditions may not prevent degradation of service in some situations. Repairs to certified equipment should be coordinated by a representative designated by the supplier. Any repairs or alterations made by the user to this equipment, or equipment malfunctions, may give the telecommunications company cause to request the user to disconnect the equipment. Users should ensure for their own protection that the electrical ground connections of the power utility, telephone lines and internal metallic water pipe system, if present, are connected together. This precaution may be particularly important in rural areas.



CAUTION

Users should not attempt to make such connections themselves, but should contact the appropriate electric inspection authority, or electrician, as appropriate.

CP-01, Issue 8, Part I: Section 14.2

NOTICE: The **Ringer Equivalence Number** (REN) assigned to each terminal device provides an indication of the maximum number of terminals allowed to be connected to a telephone interface. The termination on an interface may consist of any combination of devices subject only to the requirement that the sum of the Ringer Equivalence Numbers of all the devices does not exceed 5.

Confidentiality Notice

This manual is provided solely as an installation, operation, and maintenance guide and contains sensitive business and technical information that is confidential and proprietary to GAI-Tronics. GAI-Tronics retains all intellectual property and other rights in or to the information contained herein, and such information may only be used in connection with the operation of your GAI-Tronics product or system. This manual may not be disclosed in any form, in whole or in part, directly or indirectly, to any third party.

Warranty

Equipment. GAI-Tronics warrants for a period of one (1) year from the date of shipment, that any GAI-Tronics equipment supplied hereunder shall be free of defects in material and workmanship, shall comply with the then-current product specifications and product literature, and if applicable, shall be fit for the purpose specified in the agreed-upon quotation or proposal document. If (a) Seller's goods prove to be defective in workmanship and/or material under normal and proper usage, or unfit for the purpose specified and agreed upon, and (b) Buyer's claim is made within the warranty period set forth above, Buyer may return such goods to GAI-Tronics' nearest depot repair facility, freight prepaid, at which time they will be repaired or replaced, at Seller's option, without charge to Buyer. Repair or replacement shall be Buyer's sole and exclusive remedy. The warranty period on any repaired or replacement equipment shall be the greater of the ninety (90) day repair warranty or one (1) year from the date the original equipment was shipped. In no event shall GAI-Tronics warranty obligations with respect to equipment exceed 100% of the total cost of the equipment supplied hereunder. Buyer may also be entitled to the manufacturer's warranty on any third-party goods supplied by GAI-Tronics hereunder. The applicability of any such third-party warranty will be determined by GAI-Tronics.

Services. Any services GAI-Tronics provides hereunder, whether directly or through subcontractors, shall be performed in accordance with the standard of care with which such services are normally provided in the industry. If the services fail to meet the applicable industry standard, GAI-Tronics will re-perform such services at no cost to buyer to correct said deficiency to Company's satisfaction provided any and all issues are identified prior to the demobilization of the Contractor's personnel from the work site. Re-performance of services shall be Buyer's sole and exclusive remedy, and in no event shall GAI-Tronics warranty obligations with respect to services exceed 100% of the total cost of the services provided hereunder.

Warranty Periods. Every claim by Buyer alleging a defect in the goods and/or services provided hereunder shall be deemed waived unless such claim is made in writing within the applicable warranty periods as set forth above. Provided, however, that if the defect complained of is latent and not discoverable within the above warranty periods, every claim arising on account of such latent defect shall be deemed waived unless it is made in writing within a reasonable time after such latent defect is or should have been discovered by Buyer.

Limitations / Exclusions. The warranties herein shall not apply to, and GAI-Tronics shall not be responsible for, any damage to the goods or failure of the services supplied hereunder, to the extent caused by Buyer's neglect, failure to follow operational and maintenance procedures provided with the equipment, or the use of technicians not specifically authorized by GAI-Tronics to maintain or service the equipment. **THE WARRANTIES AND REMEDIES CONTAINED HEREIN ARE IN LIEU OF AND EXCLUDE ALL OTHER WARRANTIES AND REMEDIES, WHETHER EXPRESS OR IMPLIED BY OPERATION OF LAW OR OTHERWISE, INCLUDING ANY WARRANTIES OF MERCHANTABILITY OR FITNESS FOR A PARTICULAR PURPOSE.**

Return Policy

If the equipment requires service, contact your Regional Service Center for a return authorization number (RA#). Equipment should be shipped prepaid to GAI-Tronics with a return authorization number and a purchase order number. If the equipment is under warranty, repairs or a replacement will be made in accordance with the warranty policy set forth above. Please include a written explanation of all defects to assist our technicians in their troubleshooting efforts.

Call 800-492-1212 (inside the USA) or 610-777-1374 (outside the USA) for help identifying the Regional Service Center closest to you.