



**GAI-TRONICS® CORPORATION**  
A HUBBELL COMPANY

# Speaker/Horn Installation for GAI-Tronics Communication Systems

---

## Confidentiality Notice

This manual is provided solely as an operational, installation, and maintenance guide and contains sensitive business and technical information that is confidential and proprietary to GAI-Tronics. GAI-Tronics retains all intellectual property and other rights in or to the information contained herein, and such information may only be used in connection with the operation of your GAI-Tronics product or system. This manual may not be disclosed in any form, in whole or in part, directly or indirectly, to any third party.

## General Information

Proper mounting and orientation of speakers are critical to the proper performance of GAI-Tronics communication systems. Paging speakers used in these systems fall into one of three categories:

- Horns supplied with separate drivers and separate, optional mounting assemblies (for the most accurate orientation)
- Horns with internal drivers and optional mounting assemblies
- Cone speaker assemblies for wall or ceiling mounting

## Speaker Mounting and Wiring

Proper speaker location and orientation are crucial to ensure proper sound distribution in operating areas. The following are some guidelines:

1. Mount horn-type speakers approximately 8 to 10 feet (2.5 to 3 meters) above the floor and fasten to any convenient support structure.
2. Do not position speakers so that they are facing each other unless they are more than 50 feet apart.
3. Orient the speaker so that a person standing in the center of the coverage area can sight directly along its axis of projection. Orient horn-type speakers installed with GAI-Tronics speaker mounting assemblies vertically and horizontally after the entire assembly is permanently mounted and wired. Adjust the vertical orientation using the two locking nuts on the U-bracket of the speaker. Adjust the horizontal orientation using the locknut on the pipe nipple assembly supporting the mounting bracket adapter.

4. If two speakers are connected to SmartSeries stations, the speakers should be located in areas with the same ambient noise level.
5. Adjust the speaker output to be 6 to 10 dB louder than the surrounding noise level. It is critical that the loudspeaker be placed as close as possible to the noise source for the following reasons:
  - As you move away from a sound source, the sound pressure level drops (attenuates) roughly 6 dB each time you double your distance from the source. Therefore, if the loudspeaker and the noise source are very close together, both loudspeaker output and noise source will attenuate at the same rate, maintaining the proportional signal-to-noise ratio.
  - If you mount the loudspeaker in an area away from the noise source, the speech will be too loud near the loudspeaker but not loud enough near the noise source.

Drivers and mounting assemblies are shipped separately from the horns. See the accompanying figures for mounting assembly details. Also refer to the *Mounting Assembly Application Chart* on page 6 for the proper assembly number to be used with each GAI-Tronics horn.

## General Wiring Guidelines

GAI-Tronics recommends its 60021-301 cable where 18 AWG wire is acceptable for speaker wiring. With a maximum outside diameter of 0.285 inches (7.3 mm), it is suitable for conduit, duct, and cable tray use. It contains a BK/W insulated conductor for the (common) connection and a W/BK insulated conductor for the 8- or 16-ohm connection.

The 60028-101 3-conductor cable is recommended where the Model 13314 Series Driver is used in order to take advantage of the driver's ground connection.

Positive voltage applied on the positive loudspeaker terminal will move the diaphragm forward. Wire all speakers in a system so that all diaphragms move in the same direction. To simplify wiring, each loudspeaker terminal is labeled. Some speakers are labeled 8 COM or 16 COM. These labels correspond to the labels inside the speaker amplifiers. For those loudspeaker terminals labeled differently, use the following wiring guideline:

- If marked with L1 and L2: L1 is the common terminal. L2 is positive and is connected to either 8 or 16, depending on the speaker rating.
- If the loudspeaker has attached cables: The white conductor is common. The black conductor is positive and is connected to either 8 or 16, depending on the speaker rating.

Normally, only one of the large horn-type speakers is connected to an amplifier. If two 16-ohm speakers must be operated from one amplifier, wire them in parallel and connect them to the 8-ohm output.

In many applications, several cone-type or smaller horn-type speakers can be driven from one amplifier. Figure 1 illustrates how two, three, or four 8-ohm units may be wired to one amplifier. Figure 2 illustrates 16-ohm unit connections to one amplifier.

Do not connect loudspeakers in series when installing them in critical broadcast areas because the failure of one speaker renders the remaining speakers inoperable. Parallel installations are preferred so that if a speaker fails, the remaining speakers connected to that amplifier will continue to operate.

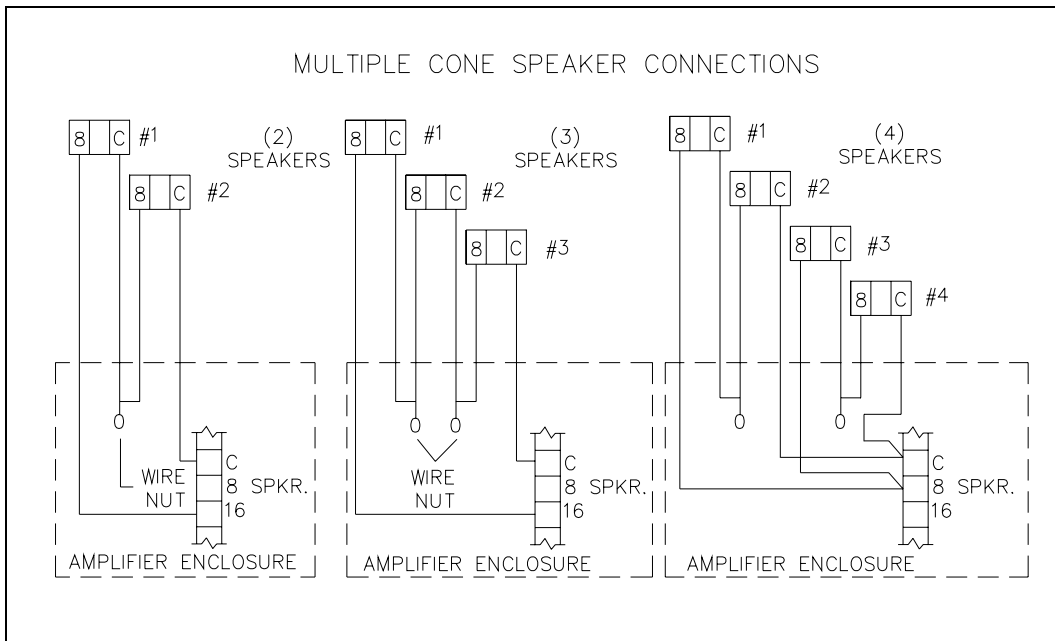

Figure 1. Cone Speaker Connections

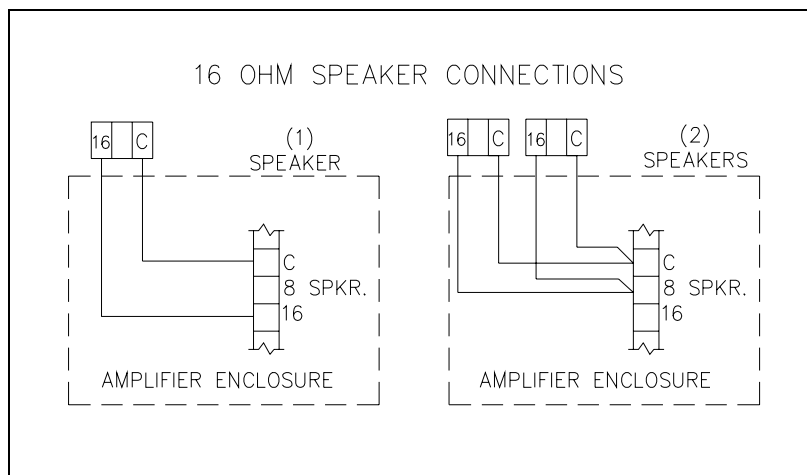

Figure 2. 16-ohm Speaker Connections

## Distributed Amplifier Systems

GAI-Tronics Page/Party® and SmartSeries systems do not use speakers with line matching transformers. The voltage on the wiring between the speaker(s) and the associated amplifiers is less than 15 V<sub>RMS</sub>, which qualifies as National Electrical Code Class II wiring. Therefore, conduit is not required except for physical protection. Cable distance should be as short as possible to reduce power loss. GAI-Tronics recommends that the cable distance between a speaker and its associated amplifier not exceed 30 feet (9.14 meters).

## Central Amplifier Systems

Central amplifier systems are generally designed to use a driver with variable-impedance, 70 volt, line matching transformer. The speaker's power level is determined by the tap settings on the transformer. Use of these transformers allows the speakers to be placed at long distances from the amplifier without significant power loss (see chart below).

The number of speakers for a central amplifier system is limited by the power available from the central amplifier. The sum of the speaker power settings must not exceed the total available from the amplifier. For example, a 250-watt central amplifier can drive 30 speakers with drivers tapped at 7.5 watts.

The following chart illustrates the correlation between the wire size and the distance that speakers with integral drivers or horns with separate drivers can be placed from a central amplifier.

Central Amplifier @ 20% Loss	
Wire size	70.7 V Line
18 AWG (0.82 mm <sup>2</sup> )	6250 feet (1903 m)
16 AWG (1.31 mm <sup>2</sup> )	9900 feet (3017 m)
14 AWG (2.08 mm <sup>2</sup> )	15,800 feet (4816 m)

## Volume Level Control and Indoor Cone Speakers

For emergency notification systems, we recommend installing speakers that have the volume control in a concealed location. A potentially dangerous situation could occur if a speaker was accidentally adjusted and an emergency broadcast was not loud enough to be heard. Therefore, to prevent tampering or accidental adjustment of the speaker level, we do not recommend the 801, 805, or 1201 Series speakers for emergency notification systems, because the volume control is accessible on the speaker housing.

**NOTE: This section does not apply to SmartSeries system applications:**

Normally, when an alarm broadcast from the Model TS958 or TS959 Multi-Tone Generator is accompanied by a VLC (50 kHz) signal, it triggers the volume on the Page/Party® VLC amplifier to increase.

However, the GAI-Tronics 804 and 1204 Series cone speaker assemblies, used primarily in indoor low ambient noise applications such as offices, have a manual wall plate volume control knob. When these speakers are powered by a Page/Party® VLC amplifier and the volume is manually turned down, the signal that increases the volume on the VLC amplifier will not bypass this manual control. The volume on these speakers remains turned down, regardless of the output signal of the amplifier, and therefore, the alarm broadcast level will not increase on the cone speaker assemblies.

## Indoor Cone Speakers

Depending on the amplifier and speaker combination used, an indoor cone speaker's volume control and speaker can be damaged due to the application of excessive power. In order to minimize the possibility of such an occurrence, use the following set-up procedure:

1. Turn the amplifier volume control all the way down (full counterclockwise position) before applying power to the system. Set the speaker volume control (if applicable) to maximum loudness (full clockwise position).
2. Measure the dc resistance of the speaker using a volt-ohm meter. Read the wattage rating of the speaker and perform the following calculation:

Multiply the resistance of the speaker ( $R_{spkr}$ ) by the speaker's wattage rating ( $W_{spkr}$ ), and find the square root.

This number is the voltage (rms) limit from the amplifier to the speaker that should not be exceeded.

$$\sqrt{R_{spkr} \times W_{spkr}} = V_{rms} \text{ limit}$$

3. Apply power to the unit, and connect a 1 kHz @ 1.5  $V_{rms}$  signal into the amplifier via the page line with a voltmeter across the speaker terminals. Adjust the amplifier volume control until the voltage limit is reached.
4. The speaker volume control can then be used to reduce the speaker level to the proper listening level as changing conditions warrant.

**NOTE:** Using this procedure does not guarantee that damage will not occur to the volume control or speaker since there are other variables, but it does minimize the possibility.

Mounting Assembly Application Chart (400 Series)		
Horns	Drivers	
	13310 (Note 1)	13314
13302-002	415A	411A
13304-002	415A	411A
13305-101	413A	413A
13306-101 (See Note 2)	415A	411A
13340	415A	411A
HP15-8	Has integral driver—use 412B	
13328-001	Has integral driver—use 412-002	

**NOTES:**

1. When using any explosion-proof speaker or driver unit, the speaker mounting assembly may be used only to support and orient the speaker. Explosion-proof fittings must be used for electrical connections.
2. When mounting the No. 13306-101 Horn in an upright orientation, the 411A mounting assembly can be used with either the 13310 or 13314 Driver. See Figure 5 on page 8.

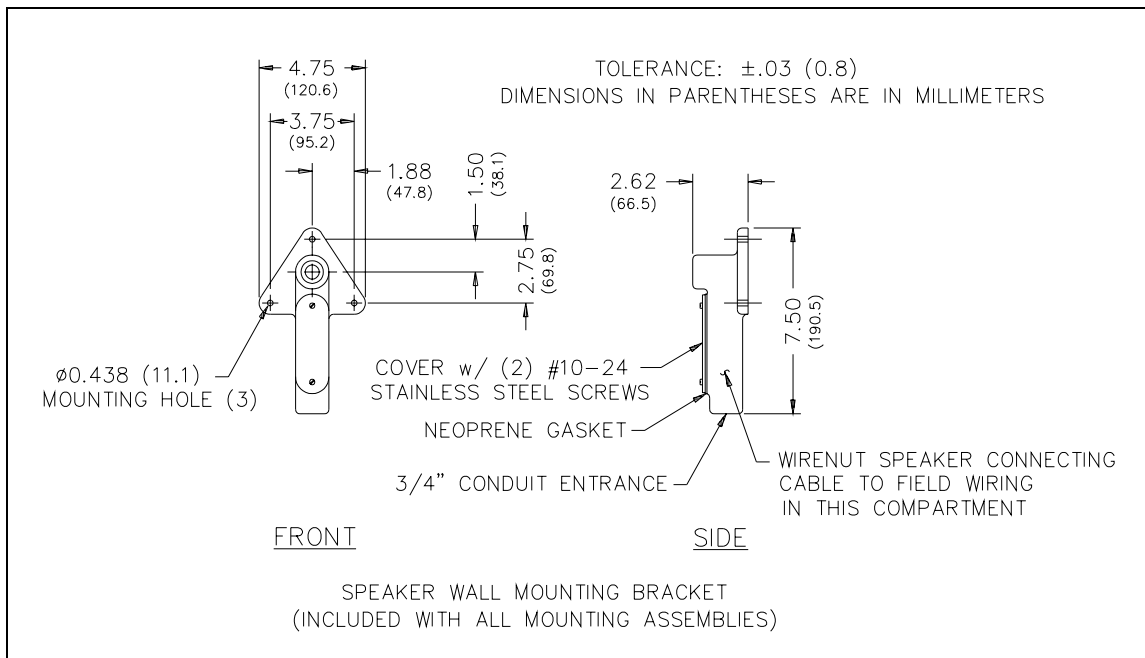

Figure 3. Wall Mounting Bracket

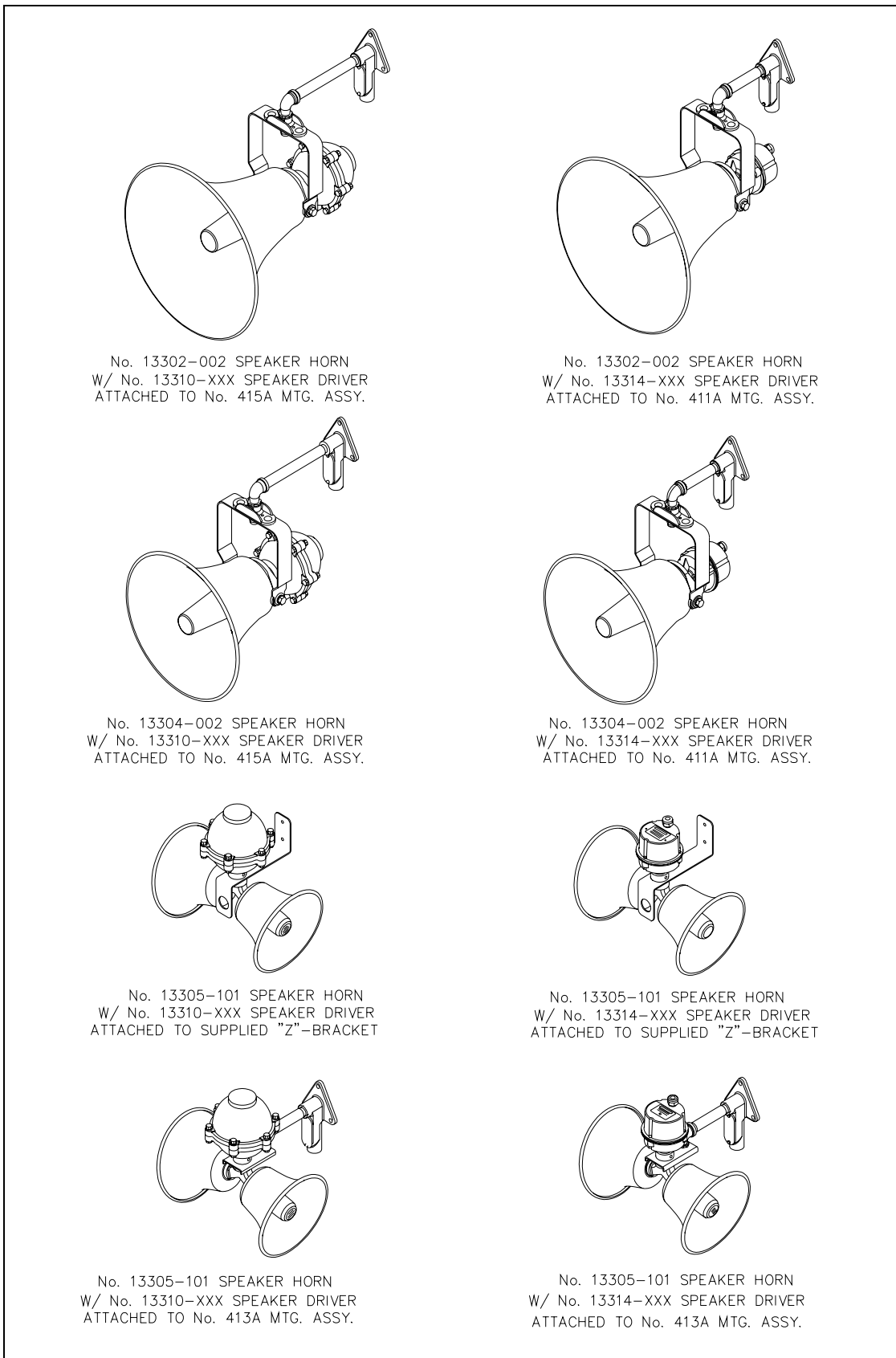

Figure 4.

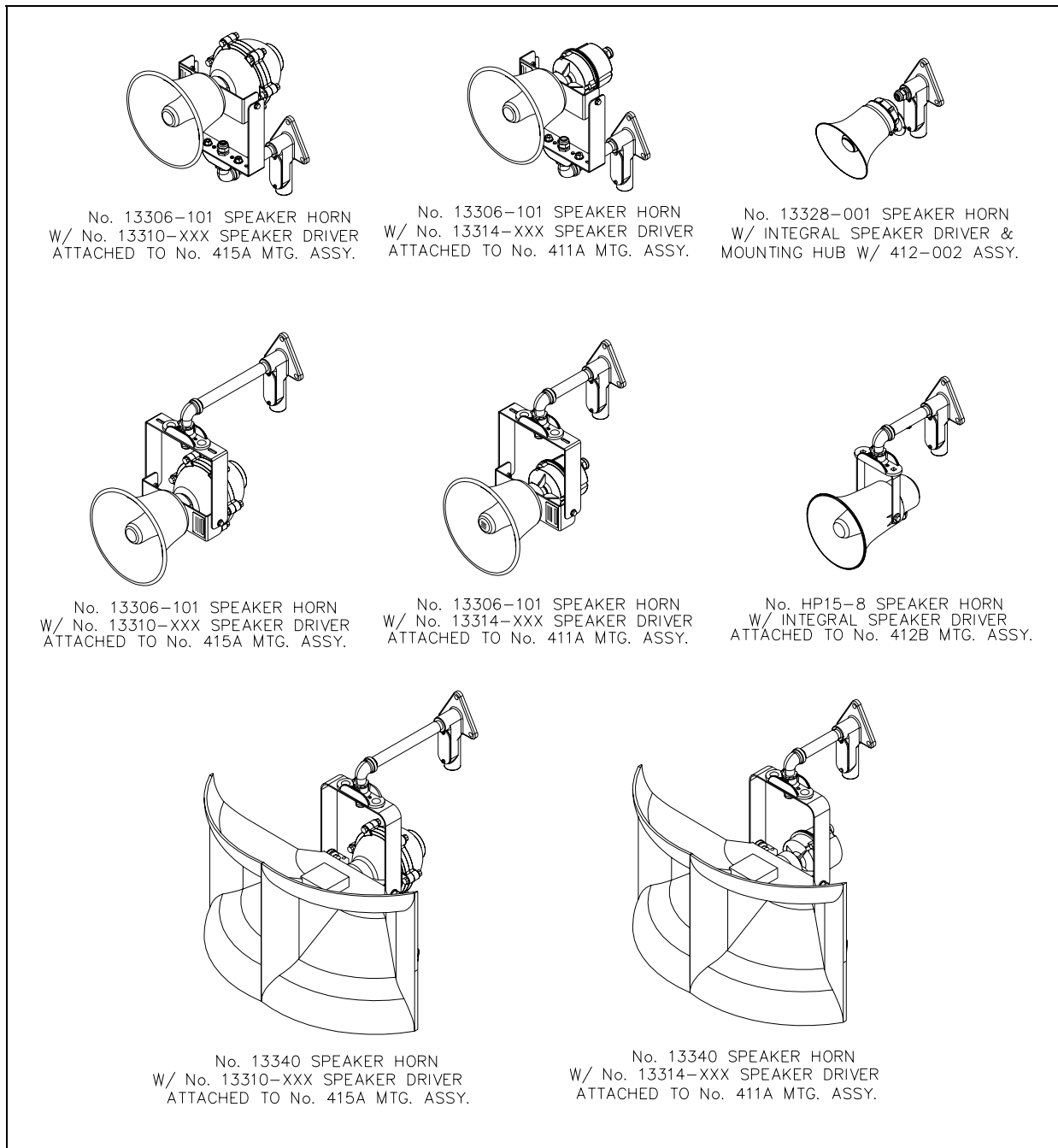

Figure 5.



# Warranty

---

Equipment. GAI-Tronics warrants for a period of one (1) year from the date of shipment, that any GAI-Tronics equipment supplied hereunder shall be free of defects in material and workmanship, shall comply with the then-current product specifications and product literature, and if applicable, shall be fit for the purpose specified in the agreed upon quotation or proposal document. If (a) Seller's goods prove to be defective in workmanship and/or material under normal and proper usage, or unfit for the purpose specified and agreed upon, and (b) Buyer's claim is made within the warranty period set forth above, Buyer may return such goods to GAI-Tronics nearest depot repair facility, freight prepaid, at which time they will be repaired or replaced, at Seller's option, without charge to Buyer. Repair or replacement shall be Buyer's sole and exclusive remedy, and the warranty period on any repaired or replacement equipment shall be one (1) year from the date the original equipment was shipped. In no event shall GAI-Tronics warranty obligations with respect to equipment exceed 100% of the total cost of the equipment supplied hereunder. Buyer may also be entitled to the manufacturer's warranty on any third-party goods supplied by GAI-Tronics hereunder. The applicability of any such third-party warranty will be determined by GAI-Tronics.

Services. Any services GAI-Tronics provides hereunder, whether directly or through subcontractors, shall be performed in accordance with the standard of care with which such services are normally provided in the industry. If the services fail to meet the applicable industry standard, GAI-Tronics will, for a period of one (1) year from the date of completion, re-perform such services at no cost to Buyer. Re-performance of services shall be Buyer's sole and exclusive remedy, and in no event shall GAI-Tronics warranty obligations with respect to services exceed 100% of the total cost of services provided hereunder.

Warranty Periods. Every claim by Buyer alleging a defect in the goods and/or services provided hereunder shall be deemed waived unless such claim is made in writing within the applicable warranty periods as set forth above. Provided, however, that if the defect complained of is latent and not discoverable within the above warranty periods, every claim arising on account of such latent defect shall be deemed waived unless it is made in writing within a reasonable time after such latent defect is or should have been discovered by Buyer.

Limitations / Exclusions. The warranties herein shall not apply to, and GAI-Tronics shall not be responsible for, any damage to the goods or failure of the services supplied hereunder, to the extent caused by Buyer's neglect, failure to follow operational and maintenance procedures provided with the equipment, or the use of technicians not specifically authorized by GAI-Tronics to maintain or service the equipment. **THE WARRANTIES AND REMEDIES CONTAINED HEREIN ARE IN LIEU OF AND EXCLUDE ALL OTHER WARRANTIES AND REMEDIES, WHETHER EXPRESS OR IMPLIED BY OPERATION OF LAW OR OTHERWISE, INCLUDING ANY WARRANTIES OF MERCHANTABILITY OR FITNESS FOR A PARTICULAR PURPOSE.**

# Return Policy

---

If the equipment requires service, contact your Regional Service Center for a return authorization number (RA#). Equipment should be shipped prepaid to GAI-Tronics with a return authorization number and a purchase order number. If the equipment is under warranty, repairs or a replacement will be made in accordance with the warranty policy set forth above. Please include a written explanation of all defects to assist our technicians in their troubleshooting efforts.

Call 800-492-1212 (inside the USA) or 610-777-1374 (outside the USA) for help identifying the Regional Service Center closest to you.